

Submersible Pumps Series BSI



● Content

General Data

Performance scope	2
Product range	2
Typical applications	3
Working conditions	3
Scope of application	3
Definition of Model	3
Curve conditions	3
Performance curve	3
NEMA Motor	3
Material	4

Technical Data

BSI1, 50Hz	5
BSI3, 50Hz	7
BSI5, 50Hz	9
BSI8, 50Hz	11
BSI12, 50Hz	13
BSI17, 50Hz	15
BSI30, 50Hz	17
BSI42, 50Hz	19
BSI60, 50Hz	21

● Performance scope

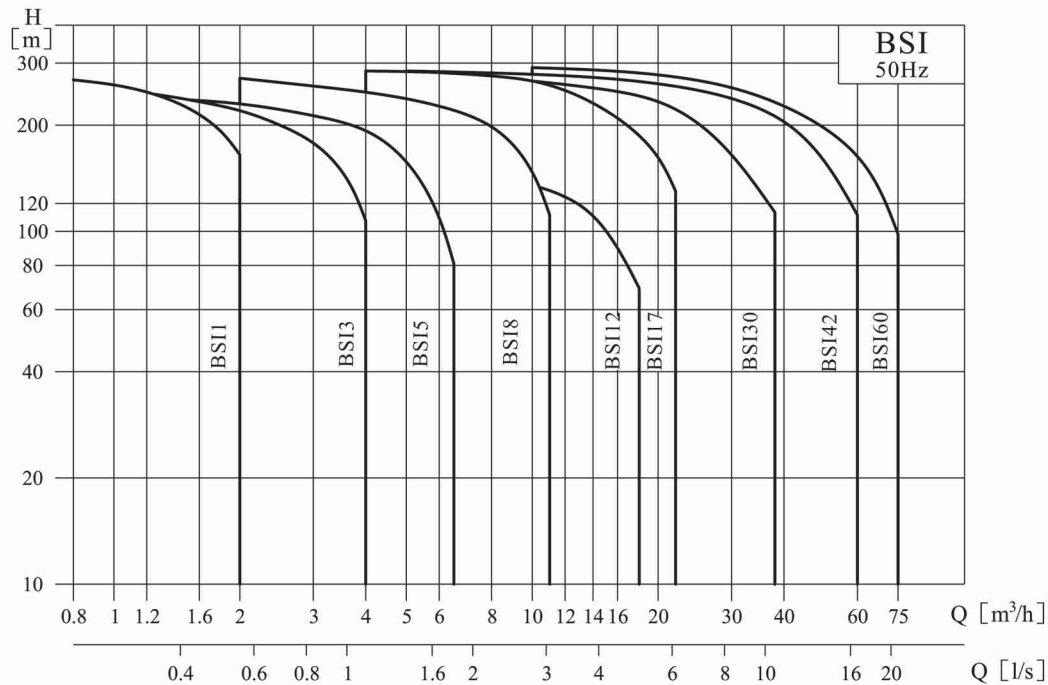

● Product range

Description	BSI1	BSI3	BSI5	BSI8	BSI12	BSI17	BSI30	BSI42	BSI60
50Hz									
Rated flow [m³/h]	1	3	5	8	12	17	30	42	60
Rated flow [l/s]	0.28	0.83	1.39	2.22	3.33	4.72	8.33	11.7	16.7
Flow range [m³/h]	0.2~2	0.8~4	1~6.5	2~11	3~18	4~22	5~38	5~60	10~75
Flow range [l/s]	0.06~0.56	0.22~1.1	0.28~1.8	0.56~3.1	0.83~5	1.11~6.1	1.39~10.6	1.39~16.7	2.8~20.8
Max pressure [bar]	28	25	24	27	16	26	28	28	29
Motor power [kW]	0.37~2.2	0.37~3	0.37~4	0.75~7.5	1.5~7.5	0.55~15	1.1~22	1.1~37	2.2~37
Max efficiency [%]	40	56	59	60	60	73	74	75	79
Pipe screw joint	Rp1 ¹ / ₄	Rp1 ¹ / ₄	Rp1 ¹ / ₂	Rp2	Rp2	Rp2 ¹ / ₂	Rp3	Rp3	Rp4

● Typical applications

- Water supply and irrigation system
- Lowering underground water
- Booster
- Various industrial applications

● Operation conditions

- Solid grain-or-fiber-free dilute clean non-corrosive liquids;
- Maximum liquid temperature: 35°C
- Maximum working pressure: 30 bar
- pH: 6.5~8.5
- Maximum diving depth: ≤50m

● Scope of application

- This series is applicable to circulation and pressurizing of the clean water and softened water;
- This series is made from stainless steel 304 and has good corrosive resistance for conveying cold water containing small amount of oxides. It is also used for conveying slightly alkaline water and de-mineralized water. Pump made from stainless steel 316 and FPM is applicable to conveying highly corrosive liquid.

● Definition of Model

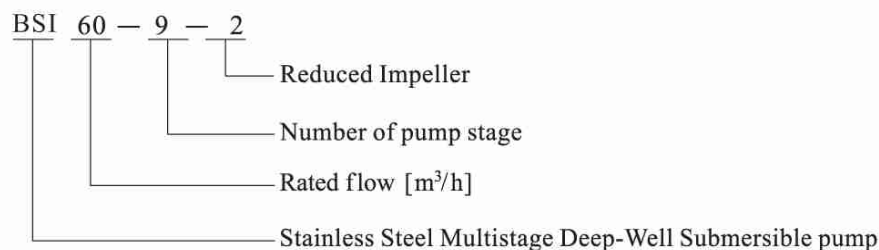
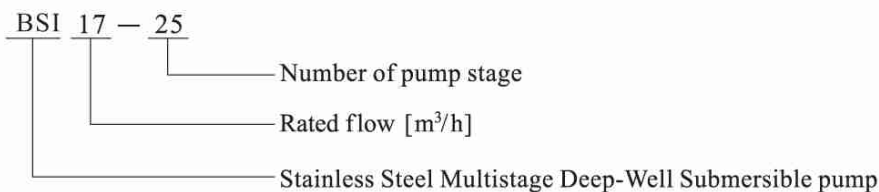

● Curve conditions

- The curve tolerance complies with ISO9906 Annex A.
- All curves are based on the measured values of 50Hz: constant motor speed 2850r/min, 60Hz: constant motor speed 3440r/min.
- All measurements are carried out with gas-free water of temperature 20°C. The curve is applicable to kinematical viscosity 1mm²/s. In case density of the liquid conveyed by the pump is higher than that of water, it is necessary to use corresponding motor of higher output power.
- The coarse part of the curve means the recommended performance scope.
- The performance curve includes loss caused by check valve etc.

● Performance curve

- Q/H curve means flow and head under the rated speed.
- Power curve: P2 means input power of each grade, Curves are shown for complete (1/1) and for reduced diameter (2/3) impellers.
- Efficiency curve: Eta means the stage efficiency of the pump

● NEMA Motor

- 4" motor, single phase, maximum power up to 1.5kW
- 4" motor, three phase, maximum power up to 7.5kW
- 6" motor, three phase, power from 4.0kW to 37 kW

● Section drawing

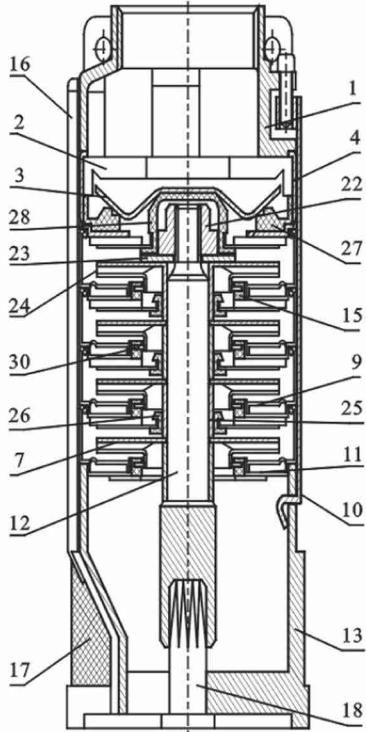

Ex.: BSI 5

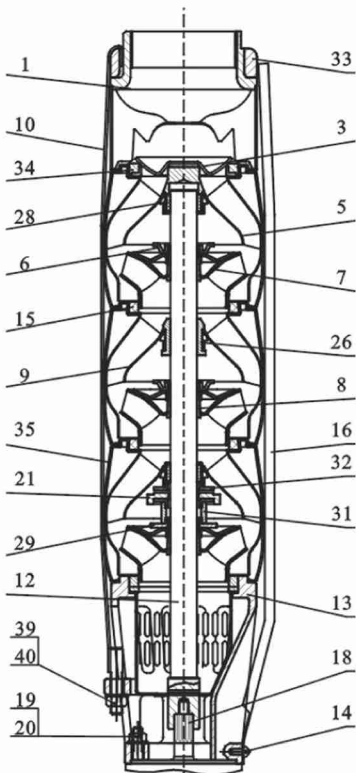

Ex.: BSI 42

● Material

NO.	Name	Material	AISI
1	Discharge head	SS304	AISI304
2	Retaining ring	SS304	AISI304
3	Valve cap	SS304	AISI304
4	Valve Body	SS304	AISI304
5	Top diffuser	SS304	AISI304
6	Impeller nut	SS304	AISI304
7	Impeller	SS304	AISI304
8	Shaft Sleeve of Impeller	SS304	AISI304
9	Diffuser	SS304	AISI304
10	Strap	SS304	AISI304
11	Inducer	SS304	AISI304
12	Pump shaft	SS304	AISI304
	Pump shaft	SS431	AISI431
13	Suction interconnector	SS304	AISI304
14	Screw	SS304	AISI304
15	Wearing seal	PVC+NBR	
16	Cable guard	SS304	AISI304
17	Strainer	SS304	AISI304
18	Motor		
19	Nut Bolt	SS304	AISI304
20	Washer	SS304	AISI304
21	Inlet Spacer	Carbon	
22	Nut	SS304	AISI304
23	Washer	SS304	AISI304
24	Outlet impeller	SS304	AISI304
25	Impeller Sleeve	SS304	AISI304
26	Shaft ring	NBR	
27	Valve Foot	NBR+SS304	
28	Uper bearing	NBR	
29	Inlet Impeller Nut	SS304	AISI304
30	Floating ring	NBR	
31	Link Sleeve	SS304	AISI304
32	Wearing Plate	SS304	AISI304
33	Outlet Housing Washer	SS304	AISI304
34	Ring outlet	SS304	AISI304
35	Inducer	SS304	AISI304
39	Washer	SS304	AISI304
40	Nut	SS304	AISI304

● Performance curve

ISO9906 Annex A

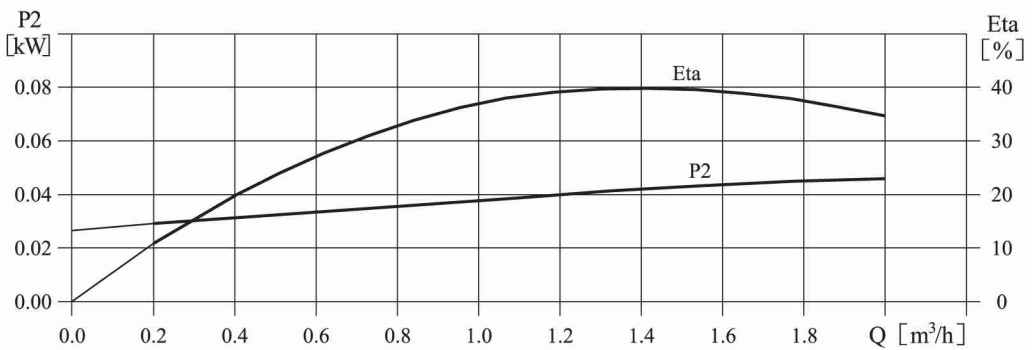
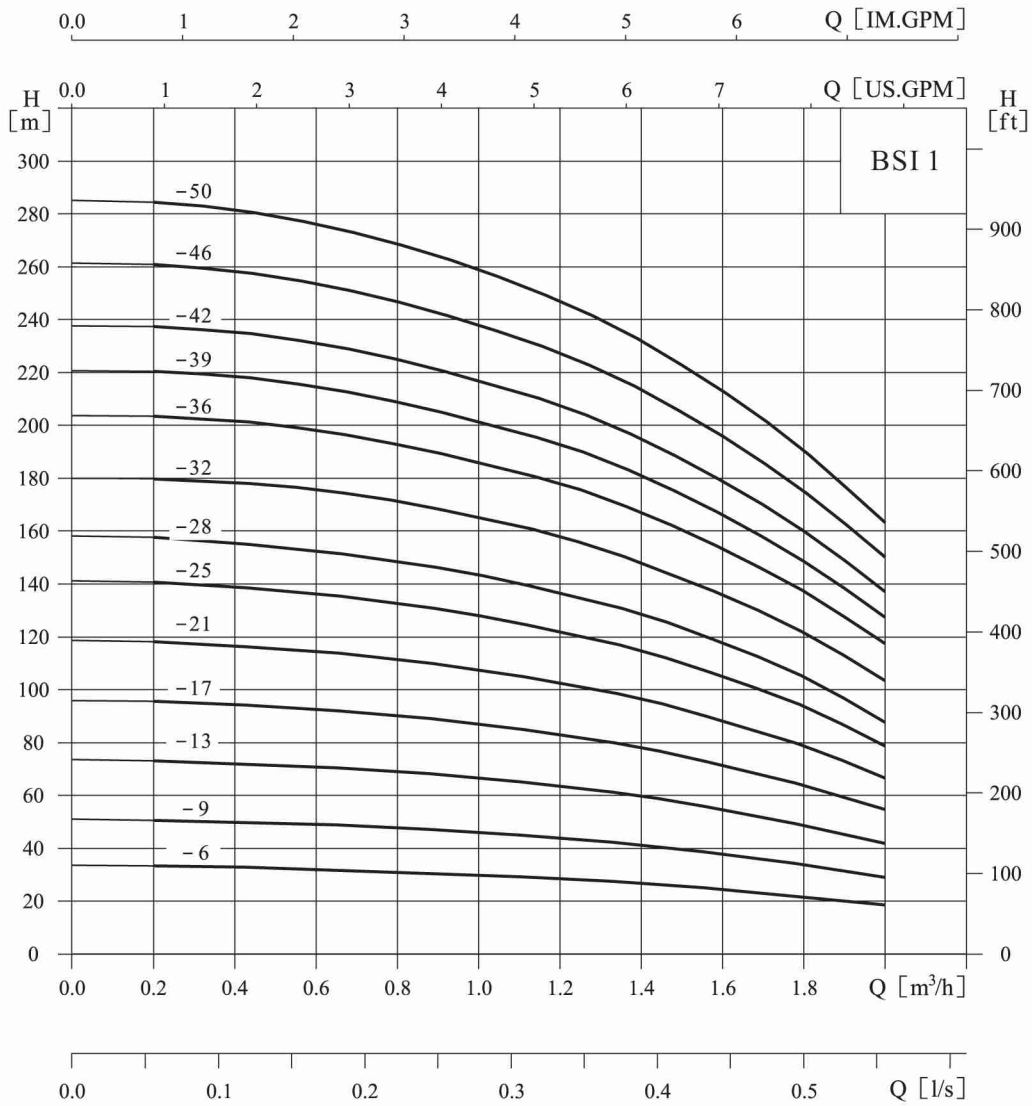

● Performance table

Model	Power (kW)	Q (m ³ /h)	0.2	0.4	0.6	0.8	1.0	1.2	1.4	1.6	1.8	2.0
BSII-6	0.37	H (m)	33.5	33	32	31	30	29	27	25	22	19
BSII-9	0.37		51	50	49	48	46	44	41	38	34	29
BSII-13	0.55		73	72	71	69	67	64	60	55	49	42
BSII-17	0.75		96	95	92	90	87	84	78	71	64	55
BSII-21	1.1		119	118	115	112	108	103	97	89	80	69
BSII-25	1.1		141	140	137	134	129	123	116	106	95	82
BSII-28	1.5		158	157	153	150	145	138	130	119	107	92
BSII-32	1.5		180	179	175	171	165	158	148	136	122	105
BSII-36	1.5		203	202	197	192	186	178	167	153	137	118
BSII-39	2.2		221	219	214	209	202	193	181	166	149	128
BSII-42	2.2		238	236	230	225	217	208	195	179	160	137
BSII-46	2.2		260	258	252	246	238	227	213	196	176	151
BSII-50	2.2		284	282	276	269	260	248	233	214	192	165

● Installation sketch

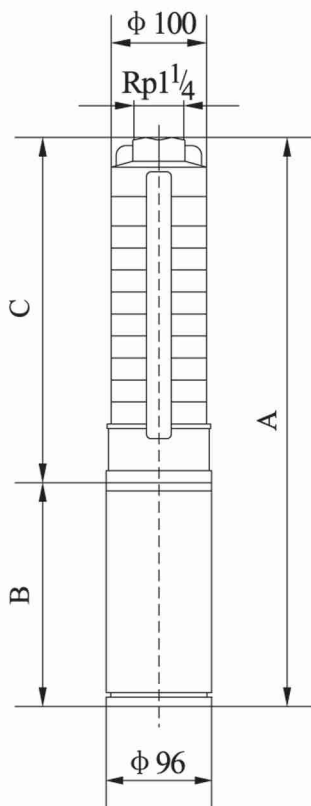

● Size and weight

Model	Size (mm)			Weight (kg)
	A	B	C	
BSII-6	667	370	297	12
BSII-9	730	370	360	13
BSII-13	824	380	444	15
BSII-17	928	400	528	17
BSII-21	1052	440	612	19
BSII-25	1136	440	696	20
BSII-28	1229	470	759	23
BSII-32	1313	470	843	24
BSII-36	1397	470	927	25
BSII-39	1500	510	990	29
BSII-42	1563	510	1053	30
BSII-46	1647	510	1137	31
BSII-50	1731	510	1221	32

Note: The size B is varied with the motors of different manufacturers.

● Performance curve

ISO9906 Annex A

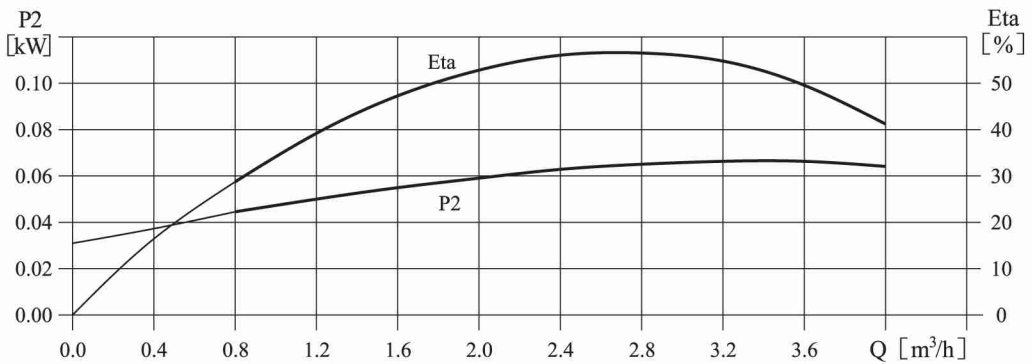
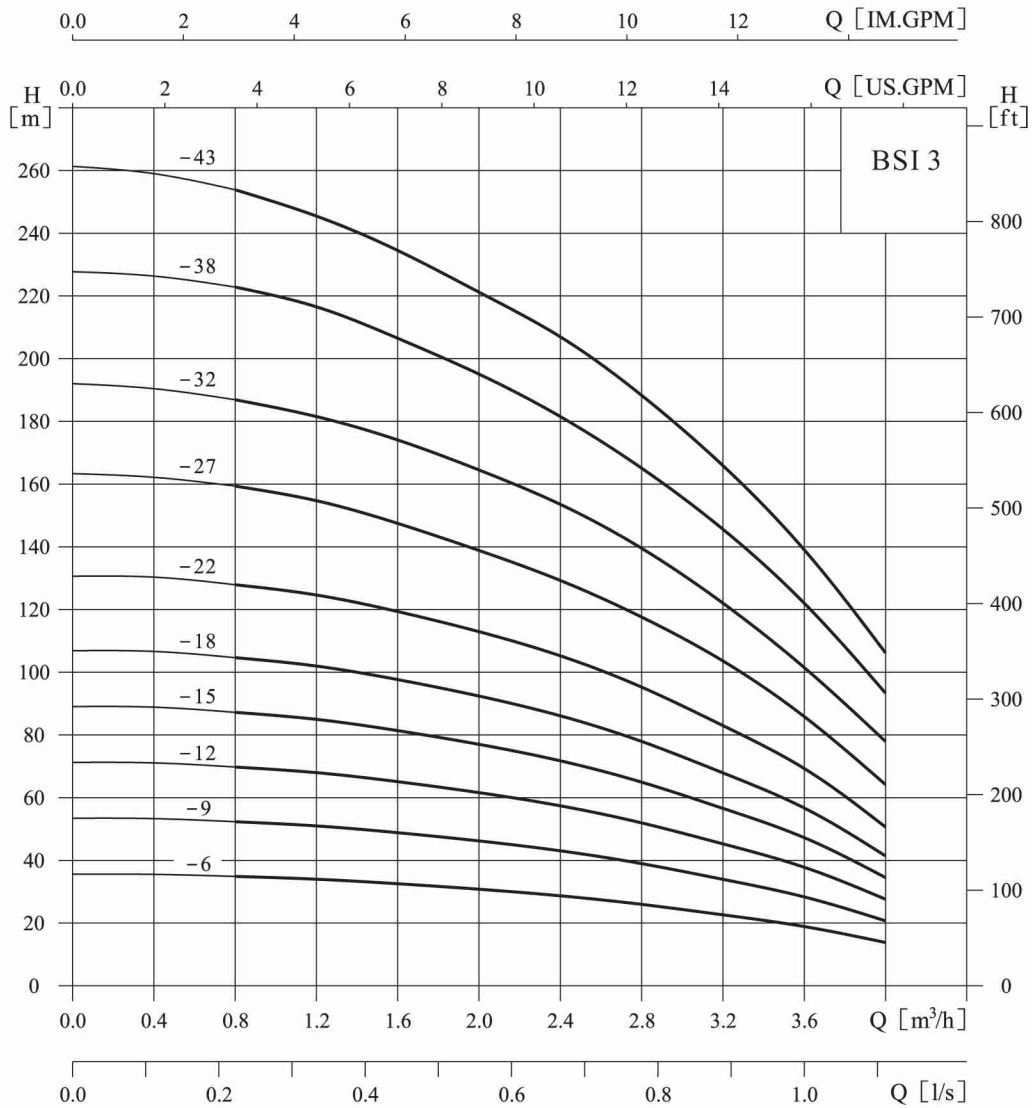

● Performance table

Model	Power (kW)	Q (m ³ /h)	0.8	1.2	1.6	2.0	2.4	2.8	3.0	3.2	3.6	4.0
BSI3-6	0.37	H (m)	36	34	32	30	28	26	24	23	18	13
BSI3-9	0.55		53	51	48	45	42	38	36	33	27	20
BSI3-12	0.75		70	68	64	61	57	52	49	44	37	27
BSI3-15	1.1		87	85	81	77	72	65	61	56	47	34
BSI3-18	1.1		105	103	97	92	87	78	74	68	57	42
BSI3-22	1.5		130	126	120	113	106	96	91	84	70	53
BSI3-27	2.2		159	154	146	138	130	118	111	104	87	66
BSI3-32	2.2		189	183	173	163	154	140	131	122	102	79
BSI3-38	3.0		224	217	205	194	183	168	157	146	122	94
BSI3-43	3.0		254	246	233	220	207	190	178	166	139	107

● Installation sketch

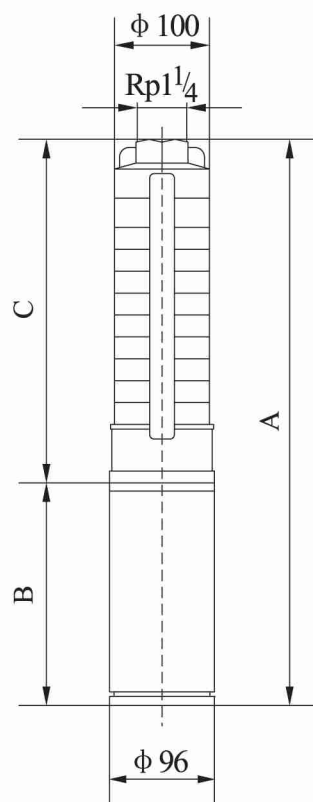

● Size and weight

Model	Size (mm)			Weight (kg)
	A	B	C	
BSI3-6	667	370	297	12
BSI3-9	740	380	360	13
BSI3-12	823	400	423	16
BSI3-15	926	440	486	18
BSI3-18	999	440	549	19
BSI3-22	1103	470	633	22
BSI3-27	1248	510	738	27
BSI3-32	1353	510	843	28
BSI3-38	1589	620	969	31
BSI3-43	1694	620	1074	32

Note: The size B is varied with the motors of different manufacturers.

● Performance curve

ISO9906 Annex A

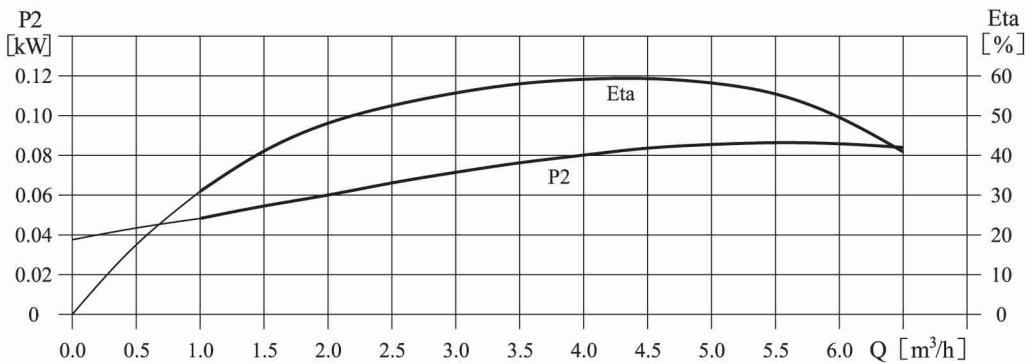
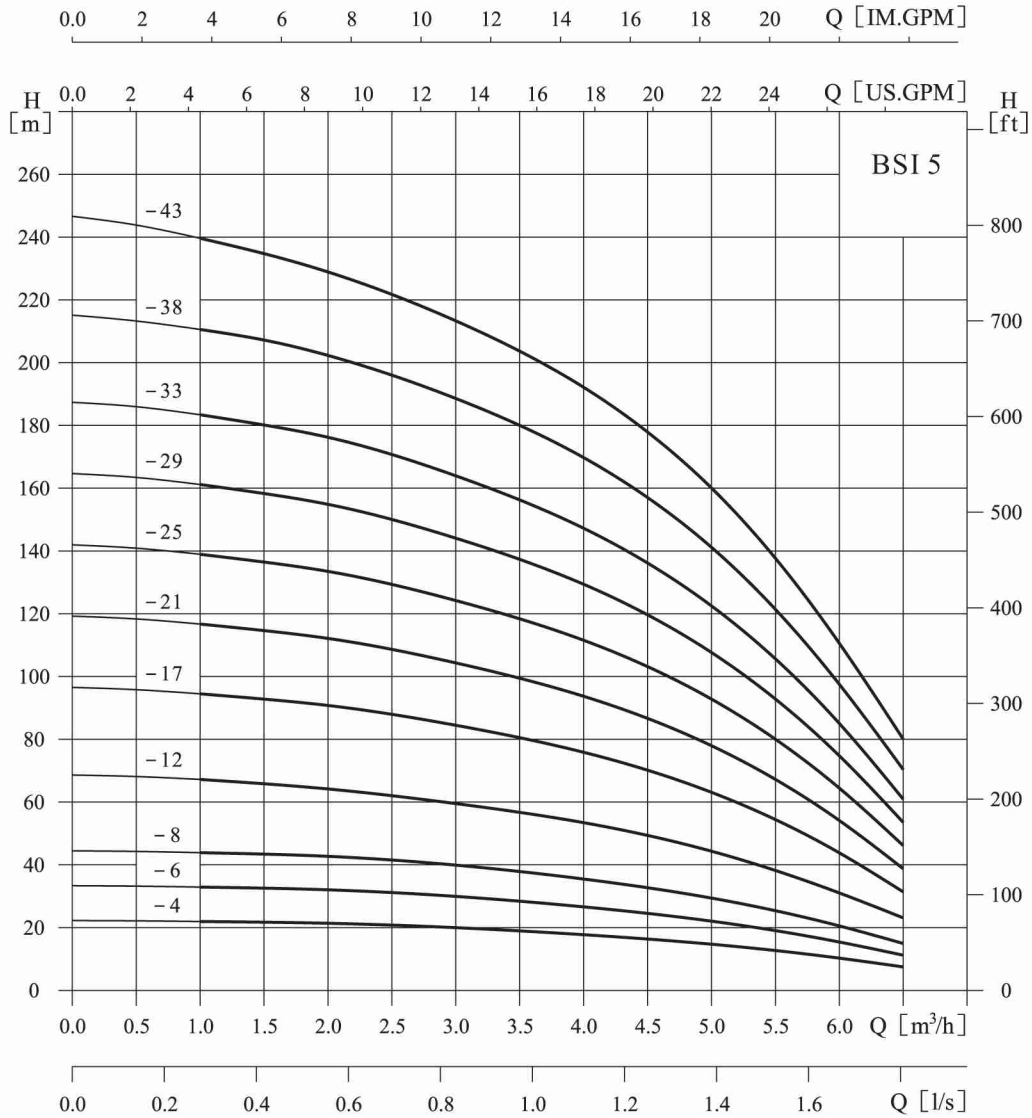

● Performance table

Model	Power (kW)	Q (m ³ /h)	1.0	2.0	3.0	3.5	4.0	4.5	5.0	5.5	6.0	6.5
BSI5-4	0.37	H (m)	21	20.5	20	19	18	17	15	13	10	8
BSI5-6	0.55		32	31	30	28	27	25	22	19	15	11
BSI5-8	0.75		43	42	40	38	36	33	30	25	20	15
BSI5-12	1.1		66	63	59	57	54	50	45	38	30	23
BSI5-17	1.5		95	91	84	80	76	71	64	54	43	32
BSI5-21	2.2		117	112	104	99	94	87	79	67	53	39
BSI5-25	2.2		139	134	124	118	112	104	94	80	64	47
BSI5-29	3.0		161	155	144	137	130	120	108	92	74	55
BSI5-33	3.0		183	177	163	156	148	137	123	105	84	62
BSI5-38	4.0		211	203	188	178	170	158	142	121	97	71
BSI5-43	4.0		239	230	213	203	193	179	161	137	109	81

● Installation sketch

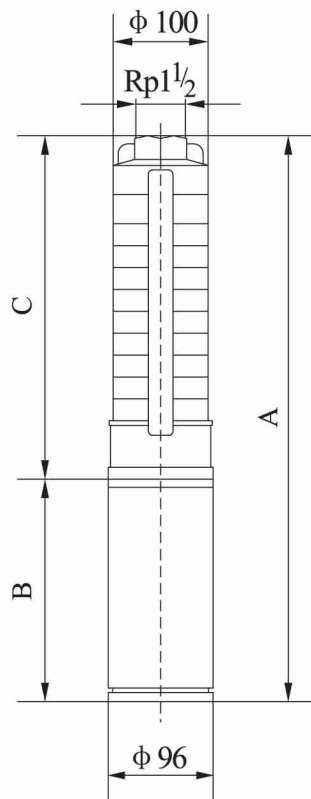

● Size and weight

Model	Size (mm)			Weight (kg)
	A	B	C	
BSI5-4	625	370	255	12
BSI5-6	677	380	297	13
BSI5-8	739	400	339	15
BSI5-12	863	440	423	17
BSI5-17	998	470	528	21
BSI5-21	1122	510	612	26
BSI5-25	1206	510	696	27
BSI5-29	1400	620	780	29
BSI5-33	1484	620	864	30
BSI5-38	1719	750	969	33
BSI5-43	1824	750	1074	35

Note: The size B is varied with the motors of different manufacturers.

● Performance curve

ISO9906 Annex A

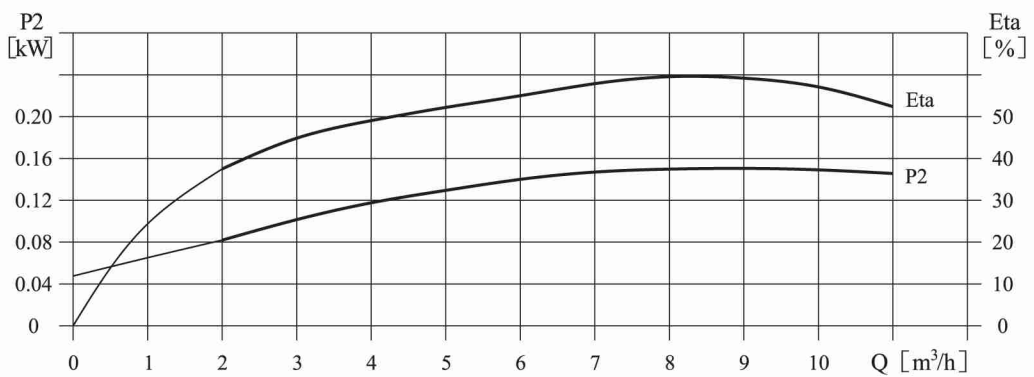
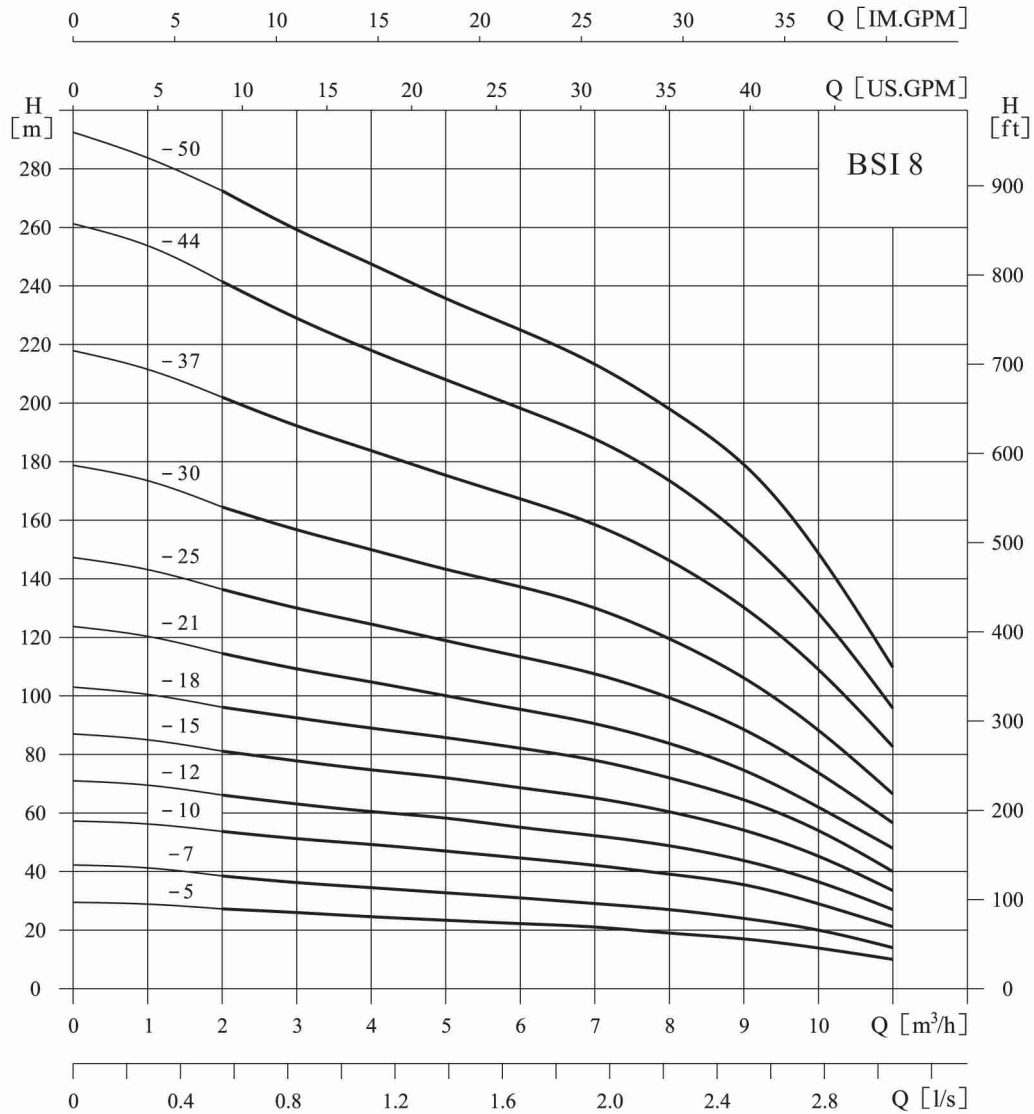

● Performance table

Model	Power (kW)	Q (m ³ /h)	2	3	4	5	6	7	8	9	10	11
BSI8-5	0.75	H (m)	27	26	24	23	22	21	19	17	14	10
BSI8-7	1.1		38	36	34	33	31	29	27	24	20	14
BSI8-10	1.5		54	52	50	47	45	42	39	35	29	21
BSI8-12	2.2		65	62	60	57	54	51	47	42	35	26
BSI8-15	2.2		81	77	74	71	68	64	59	53	44	33
BSI8-18	3.0		95	93	89	86	81	77	71	63	53	40
BSI8-21	4.0		112	108	104	100	95	90	83	74	62	47
BSI8-25	4.0		135	129	124	119	113	108	99	89	74	56
BSI8-30	5.5		162	155	149	143	136	130	119	106	88	67
BSI8-37	5.5		201	191	184	176	167	159	147	131	109	82
BSI8-44	7.5		242	227	218	209	199	190	174	156	129	98
BSI8-50	7.5		272	258	248	238	226	216	198	177	147	111

● Installation sketch

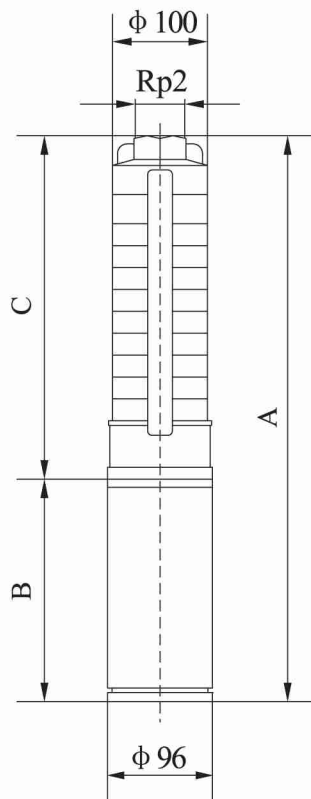

● Size and weight

Model	Size (mm)			Weight (kg)
	A	B	C	
BSI8-5	853	400	453	16
BSI8-7	977	440	537	19
BSI8-10	1133	470	663	22
BSI8-12	1257	510	747	27
BSI8-15	1383	510	873	29
BSI8-18	1619	620	999	32
BSI8-21	1875	750	1125	35
BSI8-25	2043	750	1293	37
BSI8-30	2343	840	1503	43
BSI8-37	2637	840	1797	46
BSI8-44	3011	920	2091	55
BSI8-50	3263	920	2343	58

Note: The size B is varied with the motors of different manufacturers.

● Performance curve

ISO9906 Annex A

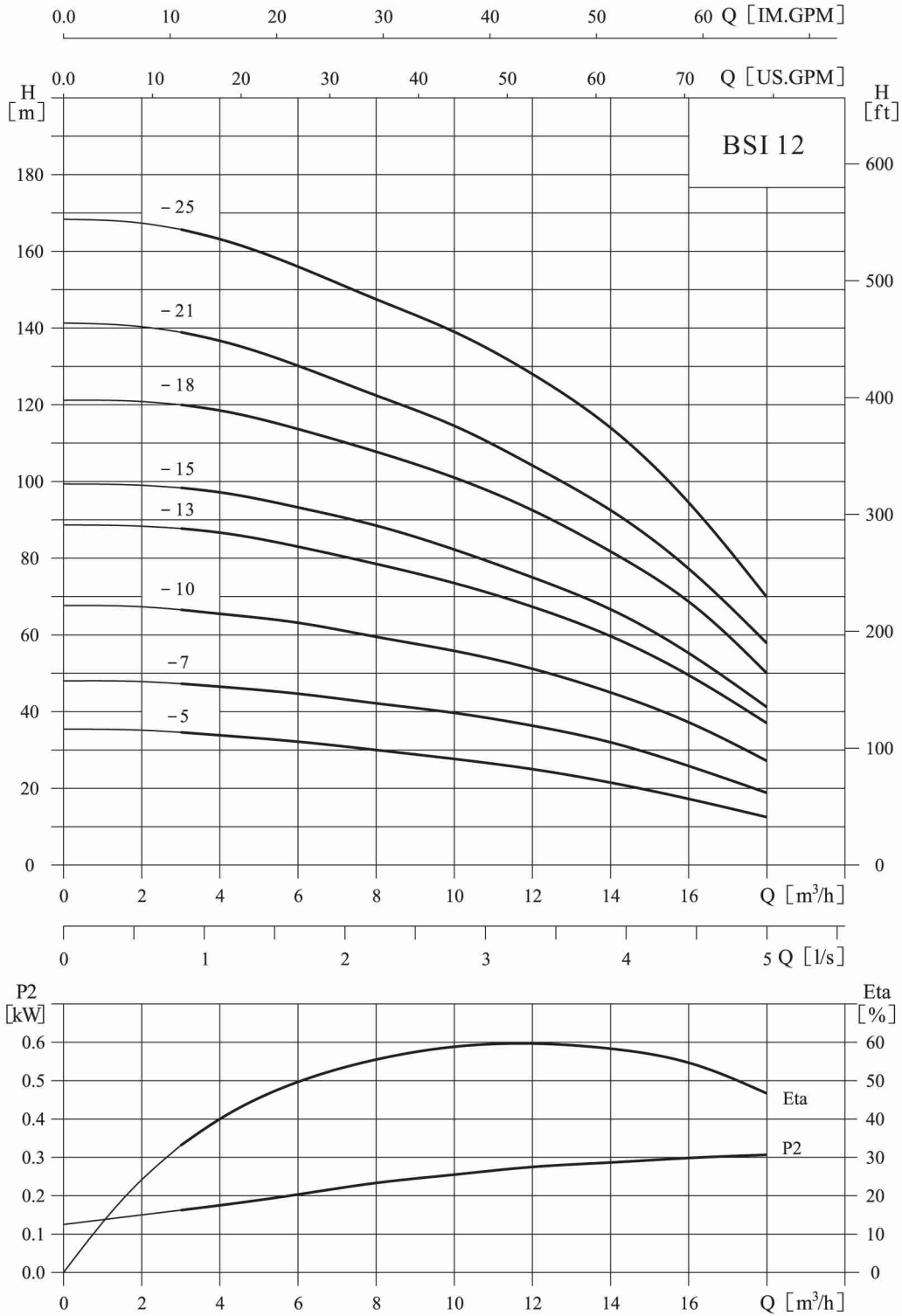

● Performance table

Model	Power (kW)	Q (m ³ /h)	3	4	6	8	10	12	14	16	18
BSI12-5	1.5	H (m)	34	33	31	29	27	25	22	18	13
BSI12-7	2.2		48	46	43	40	38	35	31	25	19
BSI12-10	3.0		67	65	62	58	55	50	45	36	27
BSI12-13	4.0		88	86	81	76	71	66	59	48	36
BSI12-15	5.5		99	97	93	88	82	76	68	55	41
BSI12-18	5.5		120	118	112	105	99	91	81	66	50
BSI12-21	7.5		138	136	130	123	115	106	95	77	58
BSI12-25	7.5		166	163	155	146	137	126	113	92	69

● Installation sketch

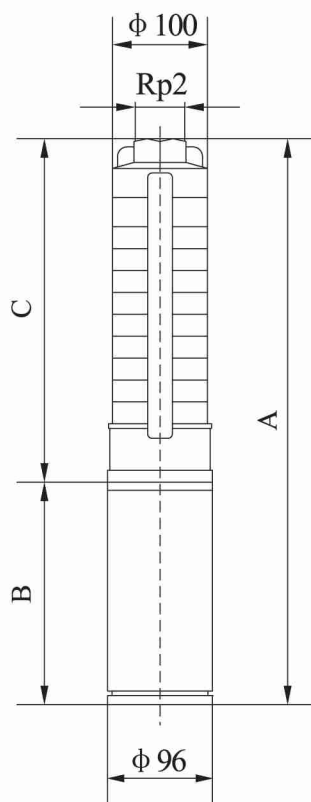

● Size and weight

Model	Size (mm)			Weight (kg)
	A	B	C	
BSI12-5	1005	470	535	21
BSI12-7	1175	510	665	26
BSI12-10	1480	620	860	30
BSI12-13	1805	750	1055	34
BSI12-15	2025	840	1185	38
BSI12-18	2220	840	1380	40
BSI12-21	2495	920	1575	47
BSI12-25	2755	920	1835	50

Note: The size B is varied with the motors of different manufacturers.

● Performance curve

ISO9906 Annex A

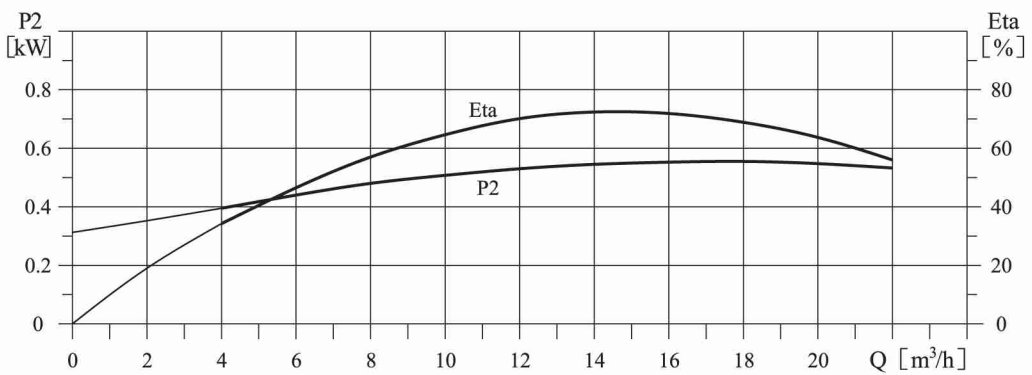
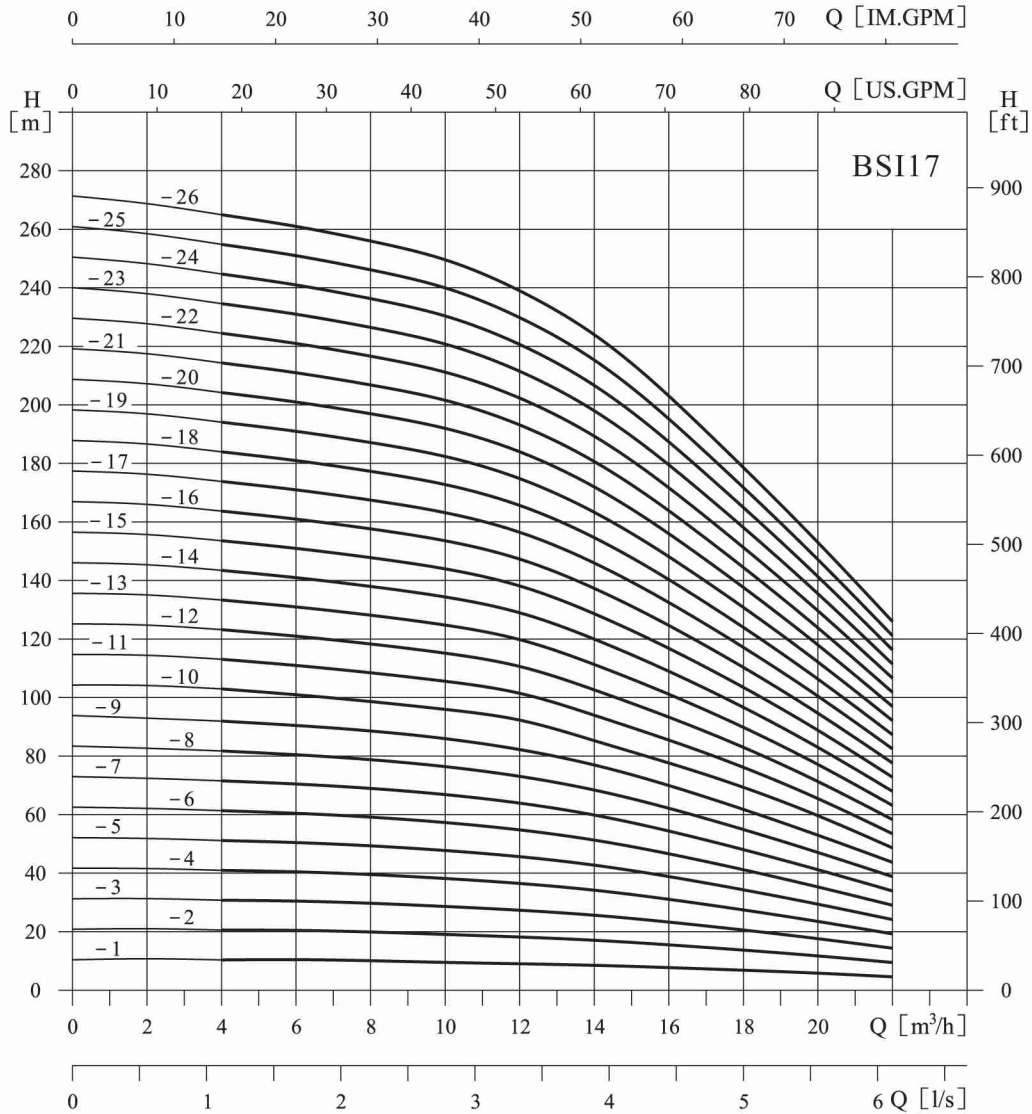

● Performance table

Model	Power (kW)	Q (m ³ /h)	4	6	8	10	12	14	17	20	22
BSI17-1	0.55	H (m)	10.5	10	9.5	9	8.5	8	6.5	5	4
BSI17-2	1.1		20.5	20	19.5	19	18	16	13.5	10.5	8
BSI17-3	2.2		31	30	29.5	28.5	27	24.5	20.5	16	13
BSI17-4	2.2		41	40	39.5	38	36.5	33.5	28	22	18
BSI17-5	3.0		52	51	50	48	45	42	35	28	23
BSI17-6	4.0		62	61	60	58	55	51	42	34	27
BSI17-7	4.0		73	71	70	67	64	59	49	40	31
BSI17-8	5.5		83	81	80	77	73	67	57	45	36
BSI17-9	5.5		93	91	90	87	82	76	64	52	40
BSI17-10	5.5		103	101	100	97	91	85	72	58	45
BSI17-11	7.5		113	111	109	106	100	94	79	64	50
BSI17-12	7.5		123	121	119	115	109	102	87	70	55
BSI17-13	7.5		133	131	129	125	118	111	95	75	60
BSI17-14	9.2		143	141	139	134	128	119	102	81	65
BSI17-15	9.2		153	151	148	144	137	128	109	87	70
BSI17-16	9.2		163	161	158	154	146	136	116	92	75
BSI17-17	9.2		173	171	167	163	155	145	123	98	79
BSI17-18	11		184	181	177	173	164	154	130	104	84
BSI17-19	11		194	191	187	182	174	162	138	110	89
BSI17-20	11		204	201	197	192	184	171	145	116	94
BSI17-21	13		214	211	207	202	193	180	152	121	99
BSI17-22	13		224	221	217	211	202	188	160	127	104
BSI17-23	13		235	231	227	221	211	197	167	133	109
BSI17-24	13		245	241	236	230	220	205	174	139	113
BSI17-25	15		255	251	246	240	229	213	181	145	118
BSI17-26	15		265	261	256	250	238	222	189	150	122

● Installation sketch

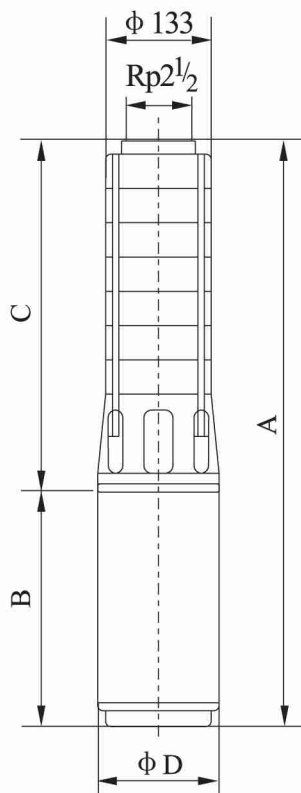

● Size and weight

Model	Size (mm)				Weight (kg)
	A	B	C	φ D	
BSI17-1	708	380	328	96	17
BSI17-2	828	440	388	96	21
BSI17-3	959	510	449	96	28
BSI17-4	1019	510	509	96	29
BSI17-5	1190	620	570	96	32
BSI17-6	1380	750	630	96/143	35/41
BSI17-7	1441	750	691	96/143	36/42
BSI17-8	1591	840	751	96/143	41/49
BSI17-9	1652	840	812	96/143	42/50
BSI17-10	1712	840	872	96/143	43/51
BSI17-11	1853	920	933	96/143	49/60
BSI17-12	1913	920	993	96/143	50/61
BSI17-13	1974	920	1054	96/143	51/62
BSI17-14	2000	870	1130	143	75
BSI17-15	2061	870	1191	143	76
BSI17-16	2121	870	1251	143	77
BSI17-17	2182	870	1312	143	78
BSI17-18	2292	920	1372	143	85
BSI17-19	2353	920	1433	143	86
BSI17-20	2413	920	1493	143	87
BSI17-21	2534	980	1554	143	95
BSI17-22	2594	980	1614	143	96
BSI17-23	2655	980	1675	143	98
BSI17-24	2715	980	1735	143	99
BSI17-25	2826	1030	1796	143	106
BSI17-26	2886	1030	1856	143	107

Note: The size B is varied with the motors of different manufacturers.

● Performance curve

ISO9906 Annex A

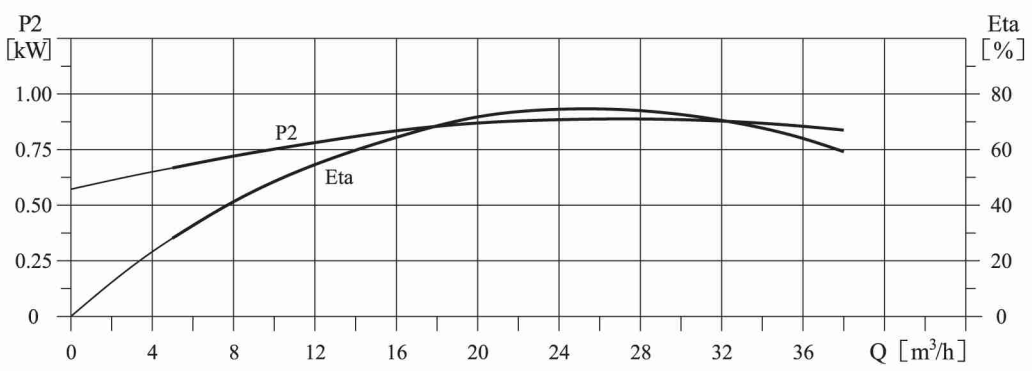
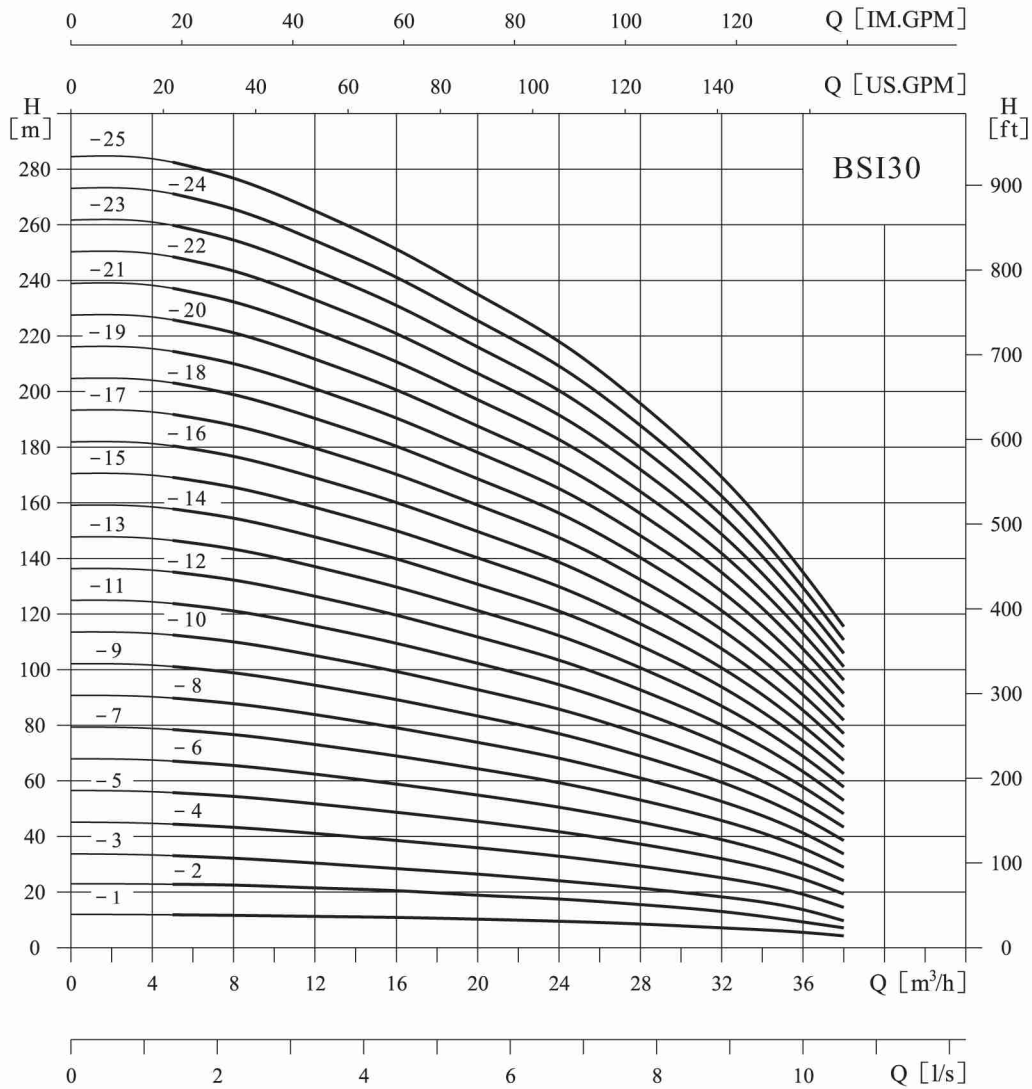

● Performance table

Model	Power (kW)	Q (m ³ /h)	5	8	12	16	20	24	28	30	32	36	38
BSI30-1	1.1	H (m)	11.5	11	10.5	10	9.5	9	8	7.5	7	5.5	4.5
BSI30-2	2.2		22.5	22	21	20	19	17.5	16	15	14	10.5	9
BSI30-3	3.0		33.5	33	32	30	28	26	24	22	20	16	14
BSI30-4	4.0		44.5	44	42	40	37	35	32	29	27	21	18
BSI30-5	5.5		55.5	55	53	50	47	44	40	37	34	27	23
BSI30-6	5.5		67	66	63	60	56	52	48	44	41	32	27
BSI30-7	7.5		77	76	74	70	65	61	55	52	48	37	32
BSI30-8	7.5		89	87	84	80	75	70	63	59	54	43	36
BSI30-9	9.2		101	98	95	90	84	78	71	66	61	48	41
BSI30-10	9.2		112	109	105	100	93	87	79	74	68	53	45
BSI30-11	9.2		123	120	116	110	103	96	87	81	75	59	50
BSI30-12	11		134	131	126	120	112	105	95	88	82	64	54
BSI30-13	11		145	142	137	129	121	113	103	96	88	69	59
BSI30-14	13		157	153	147	139	130	122	111	103	95	74	63
BSI30-15	13		168	164	158	149	140	131	119	110	102	80	68
BSI30-16	15		180	175	168	159	149	140	127	118	109	85	72
BSI30-17	15		190	186	179	169	158	148	135	125	116	90	77
BSI30-18	18.5		201	197	189	179	168	157	143	132	122	96	81
BSI30-19	18.5		212	207	200	189	177	166	150	140	129	101	86
BSI30-20	18.5		223	218	210	199	186	174	158	147	136	106	90
BSI30-21	18.5		235	229	221	209	196	183	166	155	143	112	95
BSI30-22	22		246	240	231	219	205	192	174	162	150	117	99
BSI30-23	22		258	251	242	229	214	201	182	169	156	122	104
BSI30-24	22		269	262	252	239	224	209	190	177	163	128	108
BSI30-25	22		281	273	263	249	233	218	198	184	170	133	113

● Installation sketch

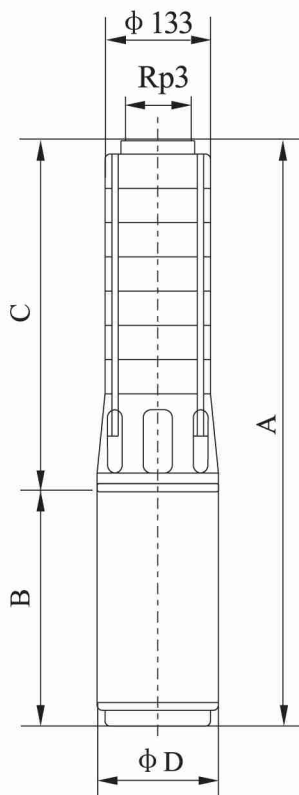

● Size and weight

Model	Size (mm)				Weight (kg)
	A	B	C	ϕD	
BSI30-1	802	440	362	96	20
BSI30-2	968	510	458	96	28
BSI30-3	1174	620	554	96	31
BSI30-4	1400	750	650	96/143	35/41
BSI30-5	1586	840	746	96/143	40/48
BSI30-6	1682	840	842	96/143	42/50
BSI30-7	1858	920	938	96/143	49/60
BSI30-8	1954	920	1034	96/143	51/61
BSI30-9	2016	870	1146	143	75
BSI30-10	2112	870	1242	143	77
BSI30-11	2208	870	1338	143	79
BSI30-12	2354	920	1434	143	85
BSI30-13	2450	920	1530	143	87
BSI30-14	2606	980	1626	143	96
BSI30-15	2702	980	1722	143	98
BSI30-16	2848	1030	1818	143	106
BSI30-17	2944	1030	1914	143	108
BSI30-18	3100	1090	2010	143	117
BSI30-19	3196	1090	2106	143	119
BSI30-20	3292	1090	2202	143	120
BSI30-21	3388	1090	2298	143	122
BSI30-22	3554	1160	2394	143	138
BSI30-23	3650	1160	2490	143	140
BSI30-24	3746	1160	2586	143	142
BSI30-25	3842	1160	2682	143	144

Note: The size B is varied with the motors of different manufacturers.

● **Performance curve**

ISO9906 Annex A

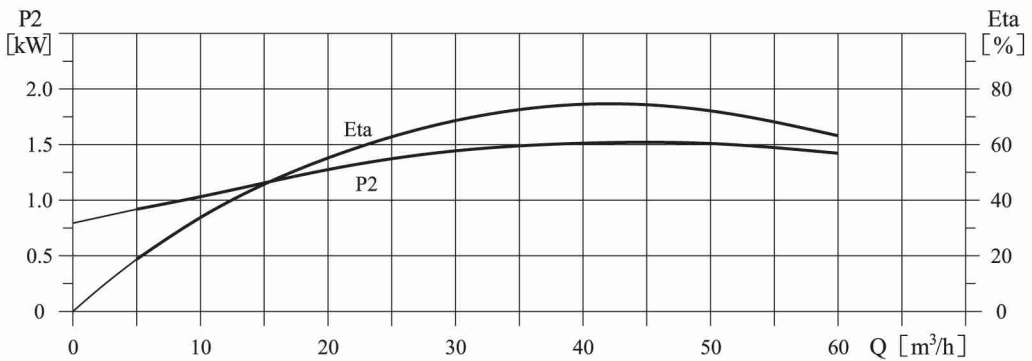
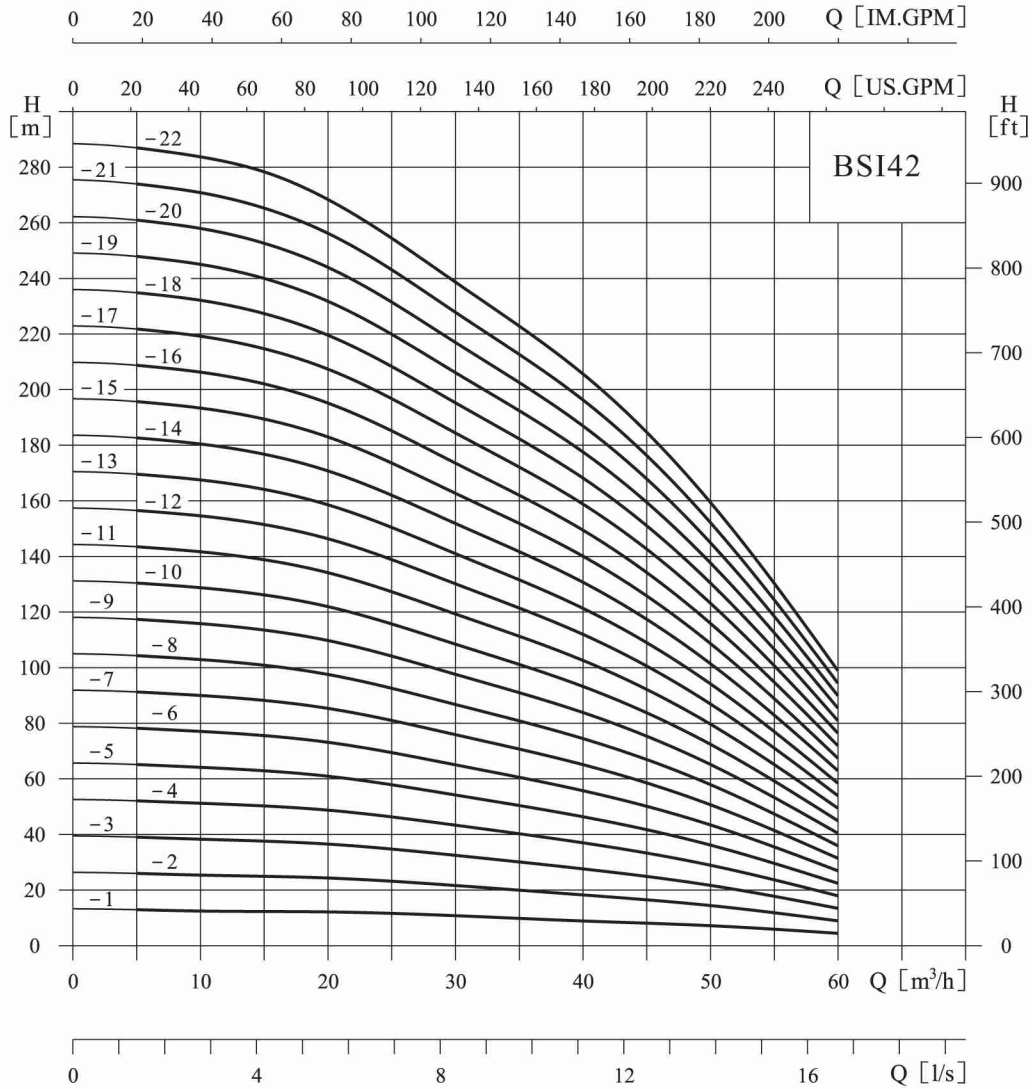

● Performance table

Model	Power (kW)	Q (m ³ /h)	5	10	20	30	40	42	50	60
BSI42-1	2.2	H (m)	13	12.5	12	10.5	9	8.5	7	4
BSI42-2	3.0		26	25.5	24	21.5	18.5	17	14.5	8.5
BSI42-3	5.5		40	38.5	36	32.5	28	26.5	22	13
BSI42-4	7.5		53	52	49	43	37	36	29	18
BSI42-5	7.5		66	65	61	54	47	45	38	23
BSI42-6	9.2		79	78	74	66	57	54	45	28
BSI42-7	11		92	91	86	77	66	63	52	32
BSI42-8	13		105	104	98	87	75	72	58	36
BSI42-9	15		118	117	110	97	84	80	65	40
BSI42-10	15		132	130	122	108	93	89	72	45
BSI42-11	18.5		144	142	134	119	103	98	79	49
BSI42-12	18.5		157	155	146	130	112	107	87	54
BSI42-13	22		170	168	158	141	122	116	94	58
BSI42-14	22		183	181	160	152	131	125	102	63
BSI42-15	22		196	194	182	163	140	134	109	67
BSI42-16	26		209	207	194	174	150	143	116	72
BSI42-17	26		222	220	206	184	159	152	123	77
BSI42-18	30		235	233	218	195	168	161	131	81
BSI42-19	30		248	246	231	206	178	170	138	86
BSI42-20	30		261	259	243	217	187	179	145	90
BSI42-21	37		274	271	255	228	196	188	152	95
BSI42-22	37		287	283	267	238	205	197	160	99

● Installation sketch

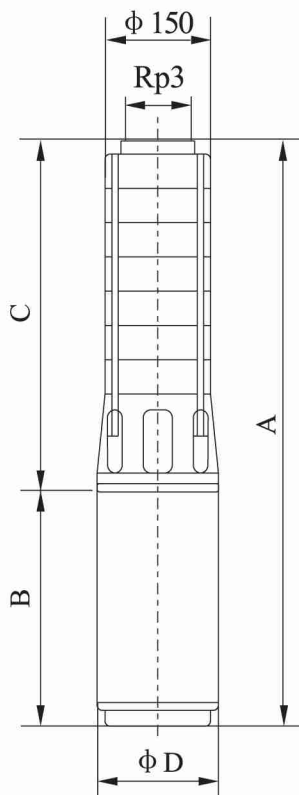

● Size and weight

Model	Size (mm)				Weight (kg)
	A	B	C	ϕD	
BSI42-1	888	510	378	96	29
BSI42-2	1111	620	491	96	33
BSI42-3	1444	840	604	96/143	40/48
BSI42-4	1637	920	717	96/143	47/58
BSI42-5	1750	920	830	96/143	49/60
BSI42-6	1829	870	959	143	73
BSI42-7	1992	920	1072	143	80
BSI42-8	2165	980	1185	143	89
BSI42-9	2328	1030	1298	143	97
BSI42-10	2441	1030	1411	143	100
BSI42-11	2614	1090	1524	143	109
BSI42-12	2727	1090	1637	143	111
BSI42-13	2910	1160	1750	143	127
BSI42-14	3023	1160	1863	143	129
BSI42-15	3136	1160	1976	143	131
BSI42-16	3319	1230	2089	143	145
BSI42-17	3432	1230	2202	143	147
BSI42-18	3645	1330	2315	143	162
BSI42-19	3758	1330	2428	143	164
BSI42-20	3871	1330	2541	143	167
BSI42-21	4224	1570	2654	143	192
BSI42-22	4337	1570	2767	143	194

Note: The size B is varied with the motors of different manufacturers.

● Performance curve

ISO9906 Annex A

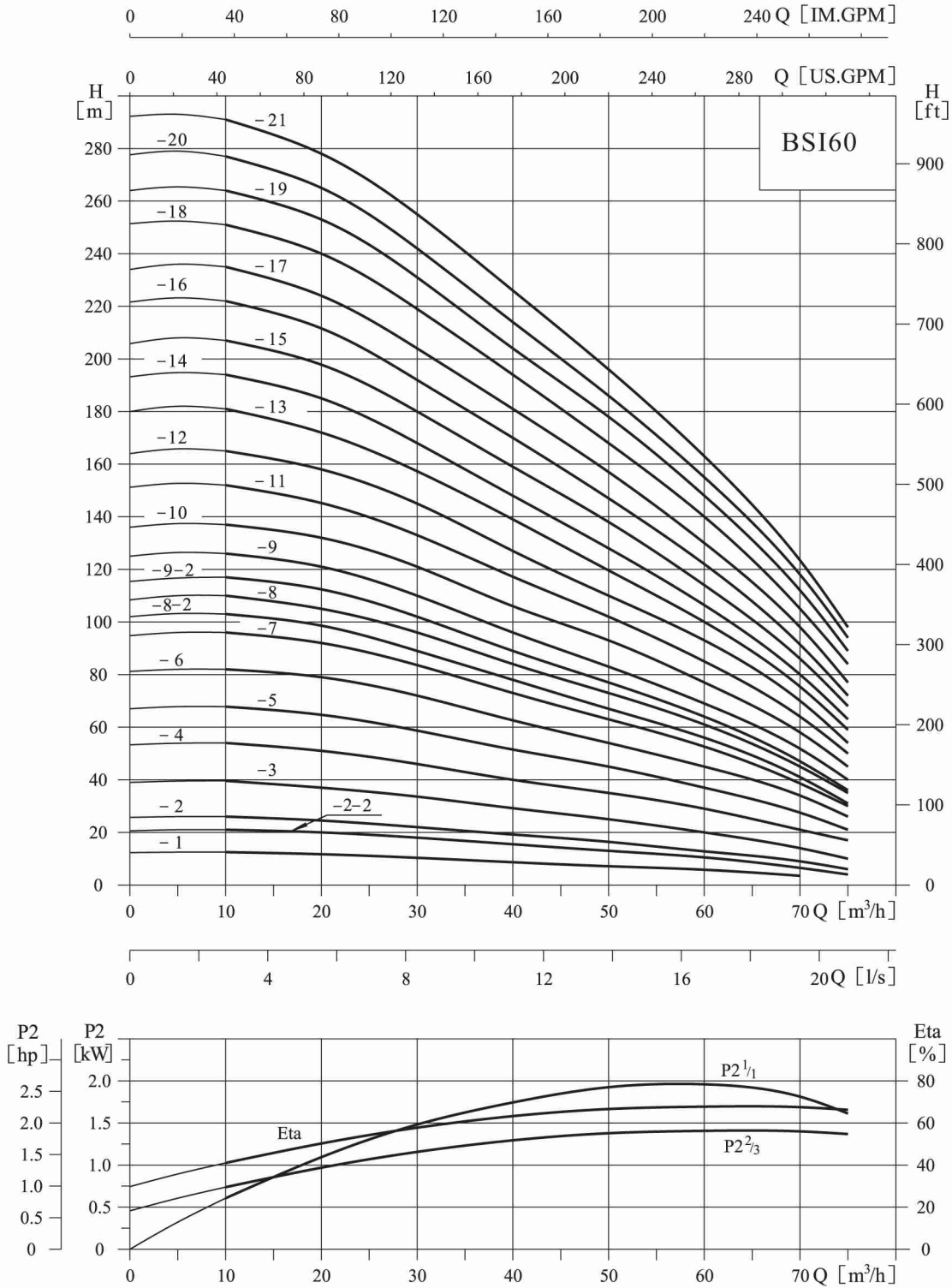

● Performance table

Model	Power (kW)	Q (m ³ /h)	10	20	30	40	50	60	70	75
BSI60-1	2.2	H (m)	12.5	12	10.5	8.5	7	6	4	–
BSI60-2-2	3.0		21	20	18	15.5	13	10.5	6.5	4
BSI60-2	4.0		26	24.5	22	19	16.5	12.5	9	6
BSI60-3	5.5		40	37	34	29	25	20	14	10
BSI60-4	7.5		54	51	46	40	35	29	21	17
BSI60-5	9.2		68	65	59	51	45	37	28	21
BSI60-6	11		82	79	72	62	54	45	34	26
BSI60-7	13		96	92	84	73	63	53	39	30
BSI60-8-2	13		103	99	89	78	67	56	41	31
BSI60-7	15		110	105	96	84	73	61	45	35
BSI60-9-2	15		117	112	102	89	77	64	47	36
BSI60-9	18.5		124	121	110	96	85	69	52	40
BSI60-10	18.5		137	132	121	106	93	77	58	45
BSI60-11	22		152	145	133	117	102	85	64	50
BSI60-12	22		165	158	145	127	110	93	70	54
BSI60-13	22		181	172	157	139	120	100	75	59
BSI60-14	25		194	185	168	148	128	106	80	63
BSI60-15	25		207	198	180	159	138	114	85	68
BSI60-16	30		222	212	192	170	147	122	91	72
BSI60-17	30		235	224	204	181	157	130	98	77
BSI60-18	30		251	240	219	194	168	140	105	84
BSI60-19	37	264	253	231	204	178	148	112	89	
BSI60-20	37	277	265	242	214	186	155	118	94	
BSI60-21	37	291	278	255	226	196	163	123	98	

● Installation sketch

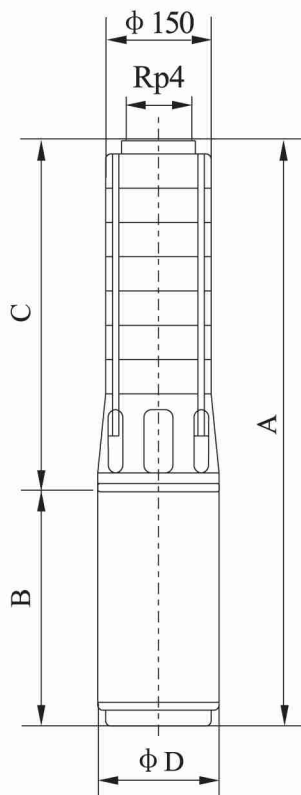

● Size and weight

Model	Size (mm)				Weight (kg)
	A	B	C	φ D	
BSI60-1	878	510	368	96	30
BSI60-2-2	1101	620	481	96	33
BSI60-2	1231	750	481	96/143	35/41
BSI60-3	1434	840	594	96/143	41/49
BSI60-4	1627	920	707	96/143	48/59
BSI60-5	1690	870	820	143	72
BSI60-6	1869	920	949	143	78
BSI60-7	2042	980	1062	143	87
BSI60-8-2	2155	980	1175	143	88
BSI60-7	2205	1030	1175	143	96
BSI60-9-2	2318	1030	1288	143	97
BSI60-9	2378	1090	1288	143	105
BSI60-10	2491	1090	1401	143	107
BSI60-11	2674	1160	1514	143	123
BSI60-12	2787	1160	1627	143	125
BSI60-13	2900	1160	1740	143	127
BSI60-14	3083	1230	1853	143	141
BSI60-15	3196	1230	1966	143	143
BSI60-16	3409	1330	2079	143	158
BSI60-17	3522	1330	2192	143	160
BSI60-18	3635	1330	2305	143	162
BSI60-19	3988	1570	2418	143	188
BSI60-20	4101	1570	2531	143	190
BSI60-21	4214	1570	2644	143	191

Note: The size B is varied with the motors of different manufacturers.



EFAFLU is a Portuguese company with more than 60 years of experience, entirely dedicated to development, manufacture, marketing, technical support as well as after-sales service of pumps, pumping systems and fans. Our products are distributed throughout Portugal and abroad by specialised and qualified partners.

We continuously develop our organisation and our products in order to provide advanced technology solutions and quality services that ensure we are the most reliable partner in the market. We are aware of the environmental problem. Accordingly, we are concerned about supplying equipment with the highest energy savings. Furthermore, we manufacture from recycled materials.

We are committed to creating value for society by betting on employees' personal valuation and fulfilment, raising the quality standards of the market and a sustained value relationship towards shareholders.

www.efafllu.pt

EFAFLU BOMBAS E VENTILADORES, S.A.

Head Office/Factory: Póvoa de Varzim
Telf.: +351 252 298 700
Fax: +351 252 615 480
e-mails: geral@efafllu.pt
vendasnorte@efafllu.pt



Lisbon Office: Miraflores - Algés, Portugal
Telf.: +351 214 134 700
Fax: +351 214 134 709
e-mail: vendassul@efafllu.pt